

2010-11 SBA Flowchart

A minimum of 82 business credits must be completed

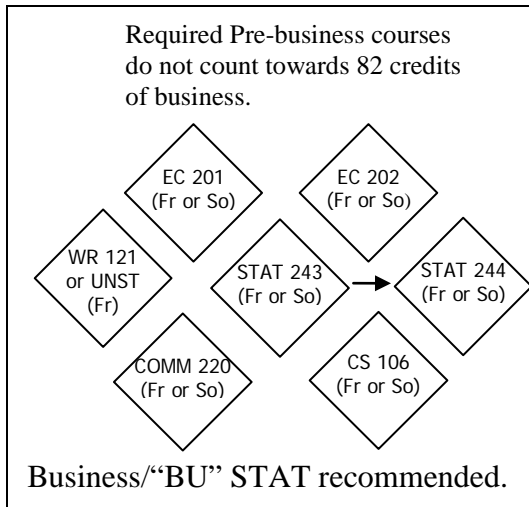

Admission to SBA required prior to taking 300/400 level business courses.

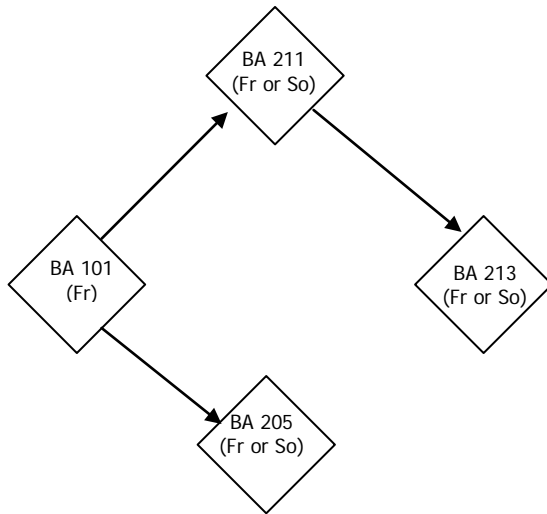
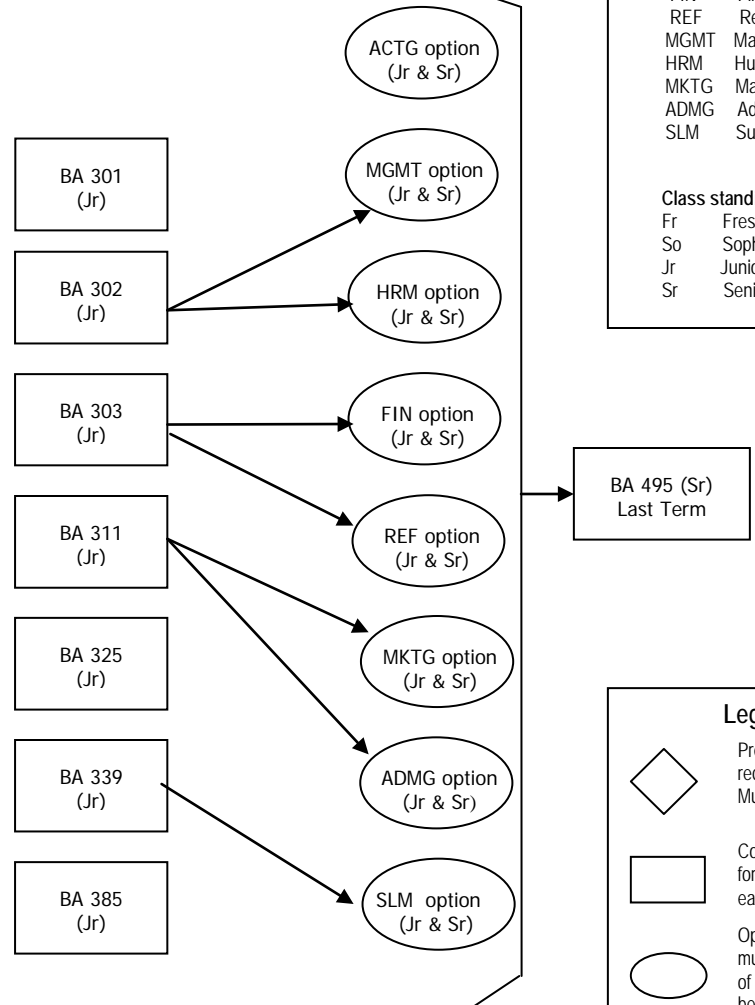

Legend of Abbreviations

Option areas:
 ACTG Accounting
 FIN Finance
 REF Real Estate Finance
 MGMT Management & Leadership
 HRM Human Resource Management
 MKTG Marketing
 ADMG Advertising Management
 SLM Supply and Logistics Management

Class standing (based on credits earned):
 Fr Freshman year (0-44 credit hours)
 So Sophomore year (45-89 credit hours)
 Jr Junior year (90-134 credit hours)
 Sr Senior Year (135+ credit hours)

Legend of Symbols

◇ Pre-business courses required for SBA Admission. Must earn a C- or better.

□ Core coursework. Required for ALL business majors. Must earn a C- or better.

○ Option areas. A student must choose a minimum of one. Must earn a C- or better.

→ Indicates the order of prerequisites. Taking courses out of order will result in a loss of credits.